

● Specification

Nominal Voltage		12V
Rated capacity (20 hour rate)		28Ah
Dimensions	Length	166mm
	Width	175mm
	Height	125mm
	Total Height	181mm
Approx. Weight		8.80kg

● Outer dimension (mm)

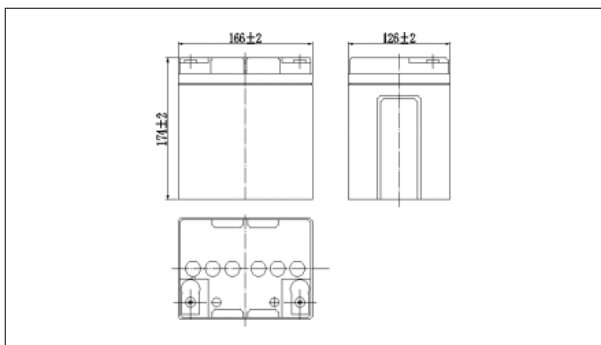

● Terminal Type (mm)

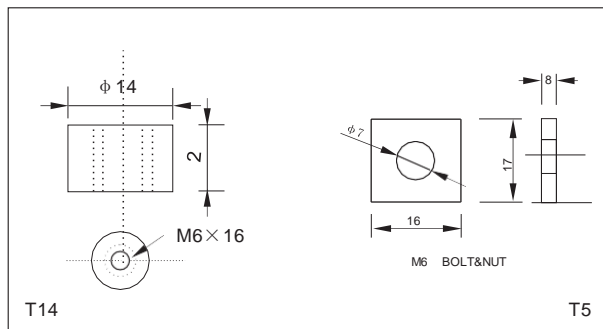

● Construction

Component	Positive plate	Negative plate	Container	Cover	Separator	Electrolyte	Safety valve	Terminal
Raw material	lead dioxide	Lead	ABS	ABS	AGM	Sulfuric acid	Rubber	Copper / lead

● Constant Current Discharge Characteristic Unit:A(25°C)

F.V/Time	5min	10min	15min	30min	60min	2h	3h	4h	5h	10h	20h
9.60V	105	66.4	51.9	29.2	18.0	10.0	6.94	5.74	4.88	2.65	1.42
9.90V	102	64.4	51.6	28.6	17.7	9.97	6.90	5.71	4.86	2.64	1.42
10.2V	97.5	61.8	48.7	27.6	17.3	9.88	6.85	5.67	4.82	2.63	1.41
10.5V	93.3	59.1	47.1	27.1	16.9	9.74	6.80	5.63	4.79	2.61	1.40
10.8V	88.0	55.8	44.6	26.1	16.4	9.49	6.60	5.46	4.64	2.56	1.37

● Constant Power Discharge Characteristic Unit:W(25°C)

F.V/Time	5min	10min	15min	30min	60min	2h	3h	4h	5h	10h	20h
9.60V	1170	749	591	335	208	117	82.4	68.4	58.3	31.8	17.1
9.90V	1135	727	577	328	205	117	82.0	68.0	58.0	31.7	17.0
10.2V	1088	697	556	318	200	116	81.4	67.5	57.6	31.5	16.9
10.5V	1041	667	537	310	196	114	80.8	67.0	57.2	31.3	16.8
10.8V	983	629	508	299	190	111	78.4	65.0	55.5	31.7	16.5

Note: The above characteristics data can be obtained within three charge or discharge cycles.



● Characteristic

Capacity (25°C)	20HR(10.5V)	28Ah
	10HR(10.5V)	26Ah
	1HR(9.60V)	17Ah
Terminal type		T12 (Insert Bolt)
Internal resistance (Fully charged,25°C)		Approx.10m Ω
Capacity affected by temperature (20HR)	40°C	102%
	25°C	100%
	0°C	85%
	-15°C	65%
Self-discharge (25°C)	3months	Remaining Capacity:91%
	6months	Remaining Capacity:82%
	12months	Remaining Capacity:65%
Nominal operating temperature		25°C
Operating temperature range	Discharge	-15°C~50°C
	Charge	-10°C~50°C
	Storage	-20°C~50°C
Float charging voltage(25°C)		13.60 to 13.80V Temperature compensation: -18mV/°C
Cyclic charging voltage(25°C)		14.50 to 15.00V Temperature compensation: -30mV/°C
Maximum charging current		8.4A
Maximum discharge current		360A(5 sec.)
Designed floating life(20°C)		5 years

VP12-28 12V28Ah

Discharge characteristics(25°C)

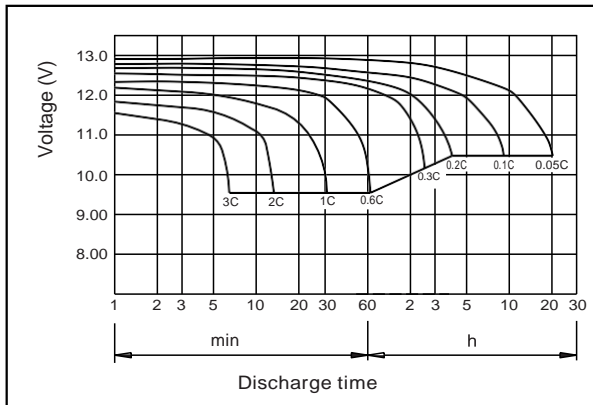

Charging characteristics

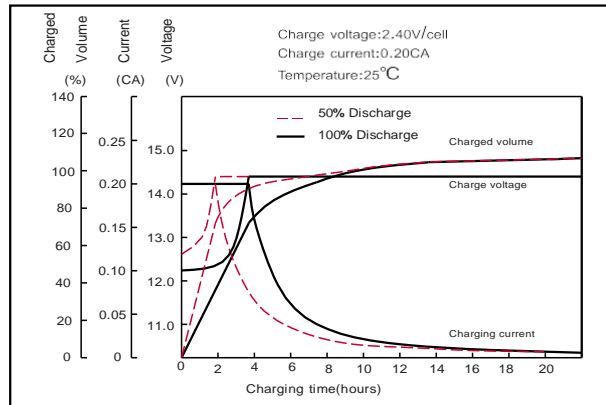

Temperature effects on Capacity

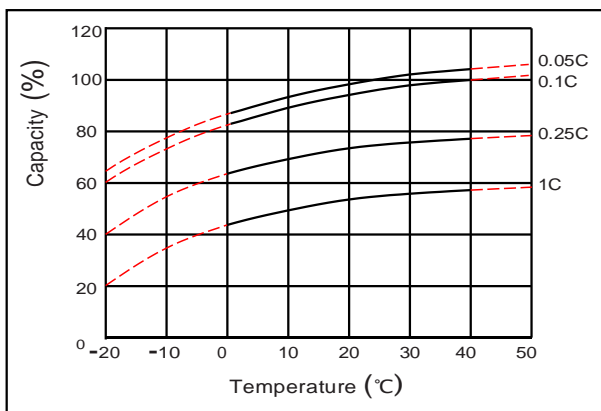

Self-discharge characteristics

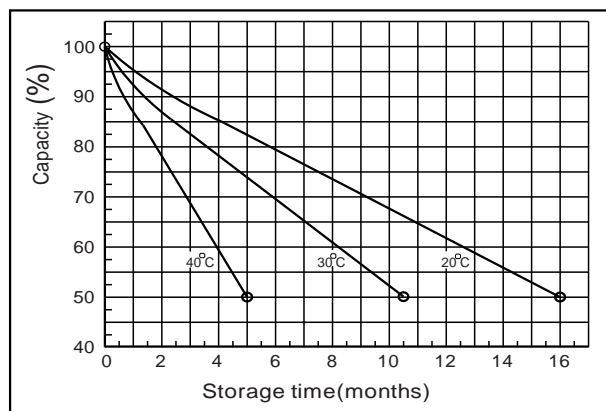

Temperature effects on float life

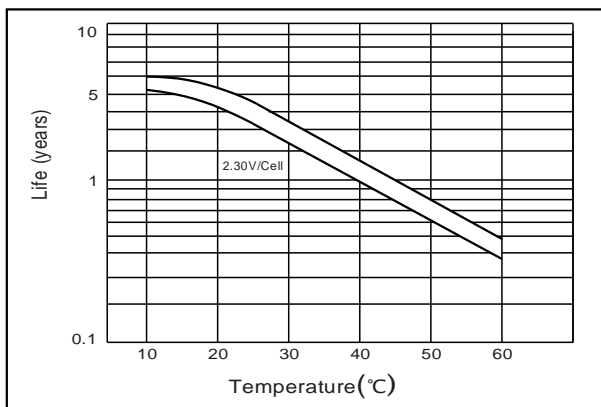

Cycle service life in relation to depth of discharge

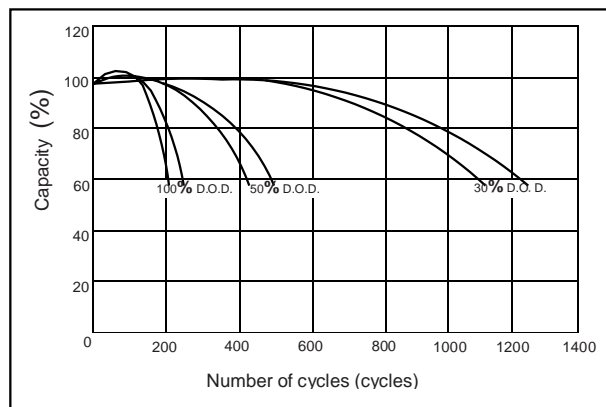

The relationship for OCV and Capacity (25°C)

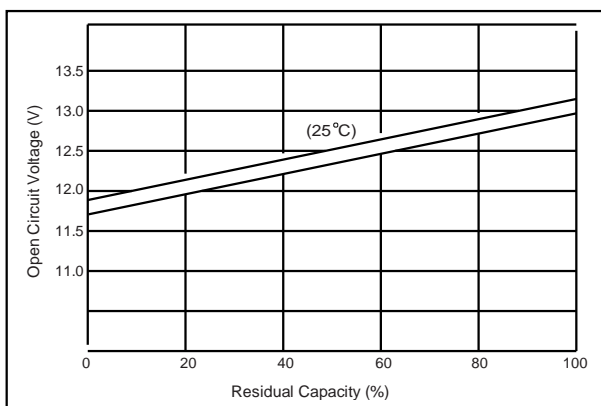

The relationship for Charging voltage and Temperature

