

● Specification

Nominal Voltage		12V
Rated capacity (20 hour rate)		5Ah
Dimensions	Length	90mm
	Width	70mm
	Height	101mm
	Total Height	107mm
Approx. Weight		1.50kg

● Outer dimension (mm)

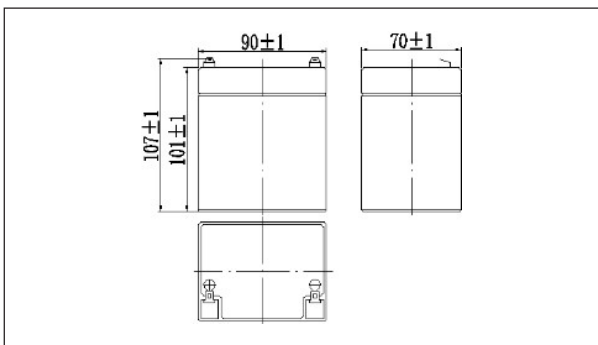

● Terminal Type (mm)

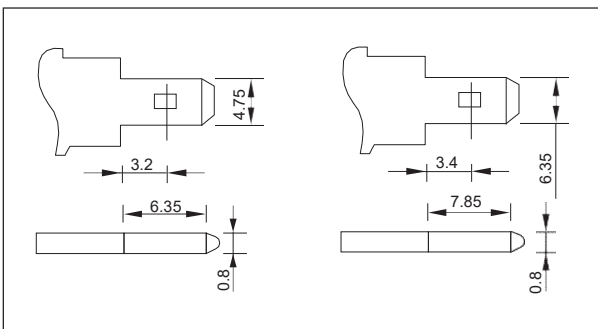

● Construction

Component	Positive plate	Negative plate	Container	Cover	Separator	Electrolyte	Safety valve	Terminal
Raw material	Lead dioxide	Lead	ABS	ABS	AGM	Sulfuric acid	Rubber	Copper

● Constant Current Discharge Characteristic Unit:A(25°C)

F.V/Time	5min	10min	15min	30min	60min	2h	3h	4h	5h	10h	20h
9.60V	19.1	12.1	9.45	5.33	3.28	1.79	1.24	1.03	0.87	0.47	0.25
9.90V	18.5	11.7	9.22	5.22	3.23	1.78	1.23	1.02	0.87	0.47	0.25
10.2V	17.8	11.3	8.88	5.06	3.14	1.77	1.22	1.01	0.86	0.47	0.25
10.5V	17.0	10.8	8.58	4.94	3.08	1.74	1.22	1.01	0.86	0.47	0.25
10.8V	16.0	10.2	8.13	4.76	2.99	1.69	1.18	0.97	0.83	0.46	0.25

● Constant Power Discharge Characteristic Unit:W(25°C)

F.V/Time	5min	10min	15min	30min	60min	2h	3h	4h	5h	10h	20h
9.60V	213	136	108	61.0	37.9	21.0	14.7	12.2	10.4	5.68	3.05
9.90V	207	132	105	59.8	37.4	20.8	14.6	12.1	10.4	5.66	3.03
10.2V	198	127	101	58.0	36.4	20.7	14.5	12.1	10.3	5.63	3.02
10.5V	190	121	97.8	56.6	35.7	20.3	14.4	12.0	10.2	5.60	3.00
10.8V	179	115	92.6	54.5	34.6	19.8	14.0	11.6	9.90	5.49	2.94

Note: The above characteristics data can be obtained within three charge or discharge cycles.



● Characteristic

Capacity (25°C)	20HR(10.5V)	5Ah
	10HR(10.5V)	4.7Ah
	1HR(9.60V)	3Ah
Terminal type		T1 (L)
Internal resistance (Fully charged, 25°C)		Approx. 27m Ω
Capacity affected by temperature (20HR)	40°C	102%
	25°C	100%
	0°C	85%
	-15°C	65%
Self-discharge (25°C)	3month	Remaining Capacity: 91%
	6month	Remaining Capacity: 82%
	12month	Remaining Capacity: 65%
Nominal operating temperature		25°C
Operating temperature range	Discharge	-15°C~50°C
	Charge	-10°C~50°C
	Storage	-20°C~50°C
Float charging voltage(25°C)		13.50 to 13.80V Temperature compensation: -18mV/°C
Cyclic charging voltage(25°C)		14.50 to 15.00V Temperature compensation: -30mV/°C
Maximum charging current		1.5A
Maximum discharge current		75A(5 sec.)
Designed floating life(20°C)		5 years

VP12-5 12V5Ah

Discharge characteristics(25°C)

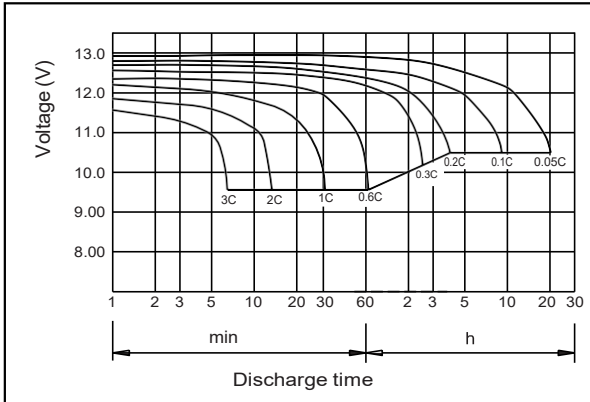

Charging characteristics (25°C)

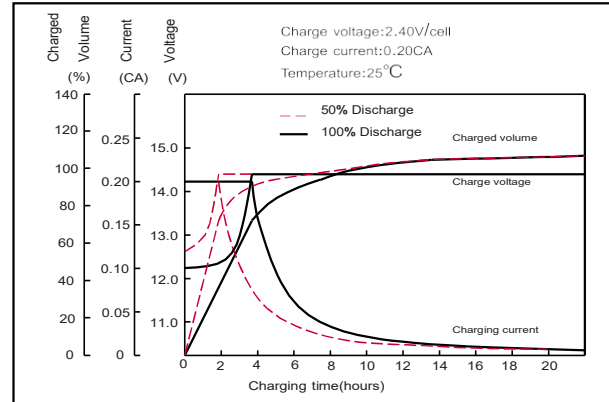

Effect of temperature on capacity

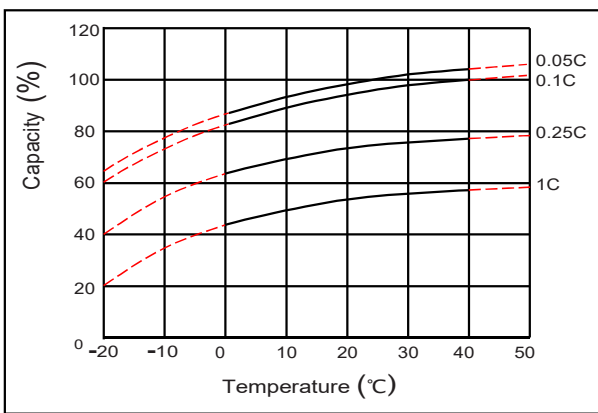

Self-discharge characteristics

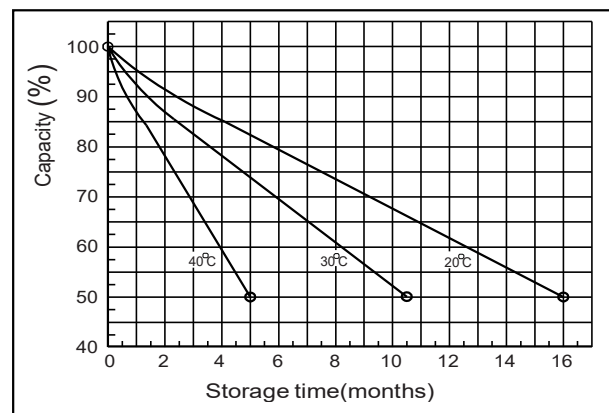

Floating life on temperature

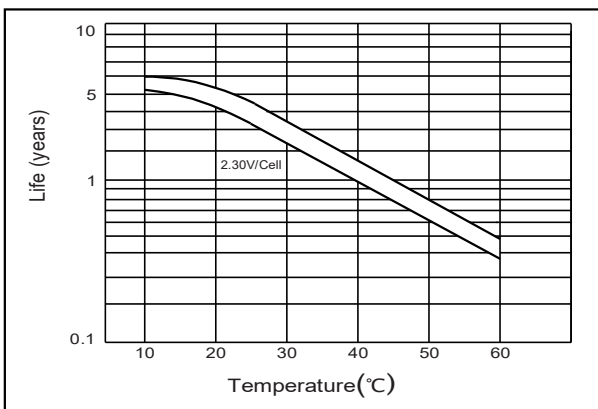

Cycle life on D.O.D(25°C)

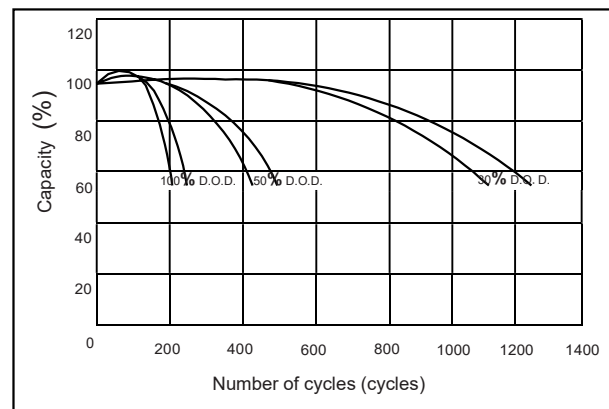

The relationship for OCV and Capacity (25°C)

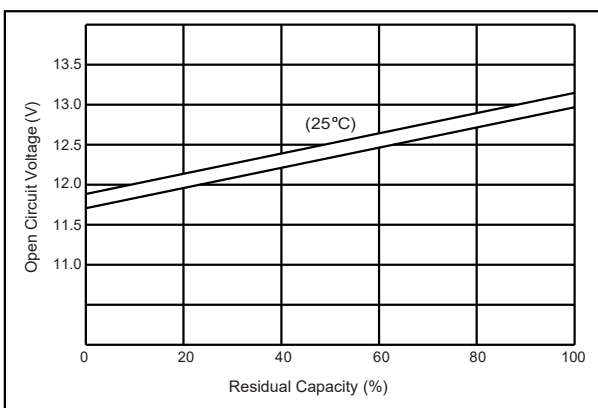

The relationship for Charging voltage and Temperature

