



VRLA BATTERY

VP12-7.5 12V7.5Ah

● Specification

Nominal Voltage	12V	
Rated capacity (20 hour rate)	7.5Ah	
Dimensions	Length	151mm
	Width	65mm
	Height	94mm
	Total Height	100mm
Approx. Weight	2.10kg	



● Outer dimension (mm)

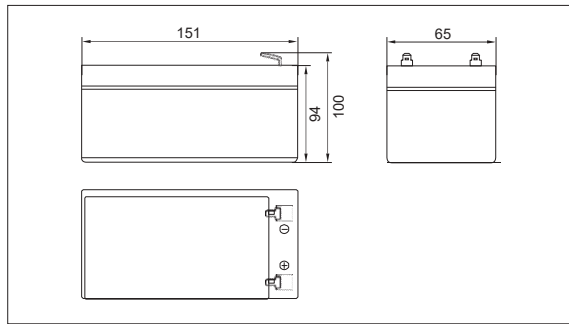

● Terminal Type (mm)

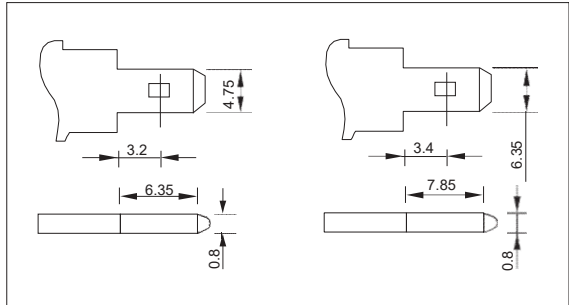

● Characteristic

Capacity (25°C)	20HR(10.5V)	7.5Ah
	10HR(10.5V)	7Ah
	1HR(9.60V)	4.6Ah
Terminal type		T2 (L)
Internal resistance (Fully charged,25°C)		Approx.21m Ω
Capacity affected by temperature (20HR)	40°C	102%
	25°C	100%
	0°C	85%
	-15°C	65%
Self-discharge (25°C)	3month	Remaining Capacity:91%
	6month	Remaining Capacity:82%
	12month	Remaining Capacity:65%
Nominal operating temperature		25°C
Operating temperature range	Discharge	-15°C~50°C
	Charge	-10°C~50°C
	Storage	-20°C~50°C
Float charging voltage(25°C)	13.60 to 13.80V Temperature compensation: -18mV/°C	
Cyclic charging voltage(25°C)	14.50 to 15.00V Temperature compensation: -30mV/°C	
Maximum charging current	2.25A	
Maximum discharge current	112.5A(5 sec.)	
Designed floating life(20°C)	5 years	

● Construction

Component	Positive plate	Negative plate	Container	Cover	Separator	Electrolyte	Safety valve	Terminal
Raw material	Lead dioxide	Lead	ABS	ABS	AGM	Sulfuric acid	Rubber	Copper

● Constant Current Discharge Characteristic Unit:A(25°C)

F.V/Time	5min	10min	15min	30min	60min	2h	3h	4h	5h	10h	20h
9.60V	28.7	18.2	14.2	7.99	4.91	2.69	1.86	1.54	1.31	0.71	0.38
9.90V	27.8	17.6	13.8	7.83	4.84	2.67	1.85	1.53	1.30	0.71	0.38
10.2V	26.6	16.9	13.3	7.59	4.72	2.65	1.84	1.52	1.29	0.70	0.38
10.5V	25.5	16.2	12.9	7.40	4.62	2.61	1.82	1.51	1.28	0.70	0.38
10.8V	24.1	15.2	12.2	7.13	4.48	2.54	1.77	1.46	1.24	0.69	0.37

● Constant Power Discharge Characteristic Unit:W(25°C)

F.V/Time	5min	10min	15min	30min	60min	2h	3h	4h	5h	10h	20h
9.60V	320	205	162	91.5	56.9	31.4	22.1	18.3	15.6	8.52	4.57
9.90V	310	199	158	89.7	56.0	31.3	22.0	18.2	15.5	8.49	4.55
10.2V	297	190	152	87.0	54.6	31.0	21.8	18.1	15.4	8.45	4.53
10.5V	285	182	147	84.9	53.5	30.5	21.7	18.0	15.3	8.40	4.50
10.8V	269	172	139	81.7	51.9	29.7	21.0	17.4	14.9	8.23	4.41

Note: The above characteristics data can be obtained within three charge or discharge cycles.

VP12-7.5 12V7.5Ah

● Discharge characteristics(25°C)

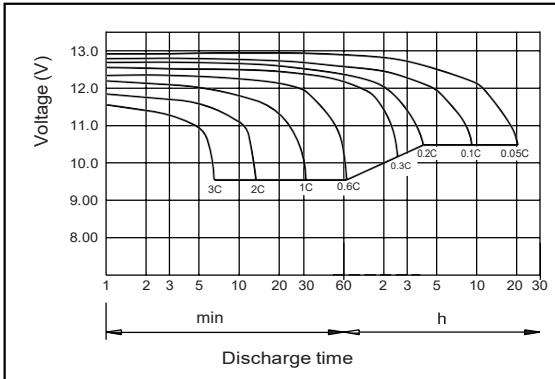

● Charging characteristics (25°C)

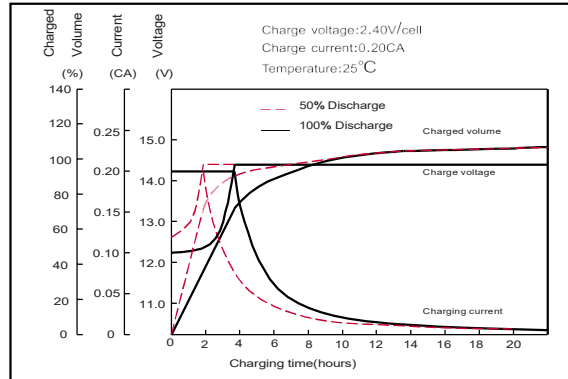

● Effect of temperature on capacity

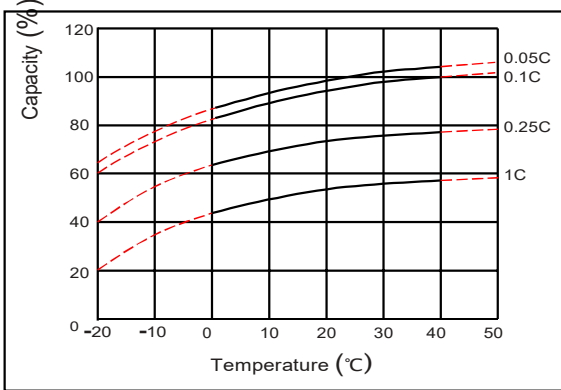

● Self-discharge characteristics

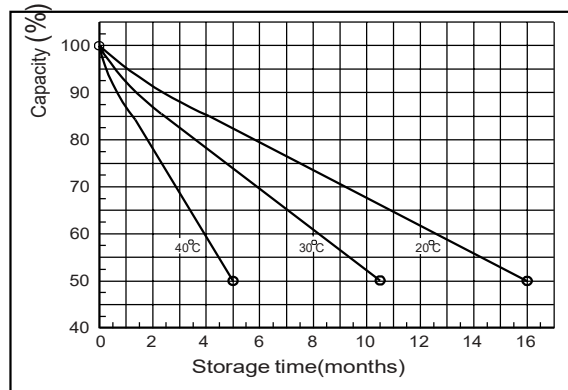

● Floating life on temperature

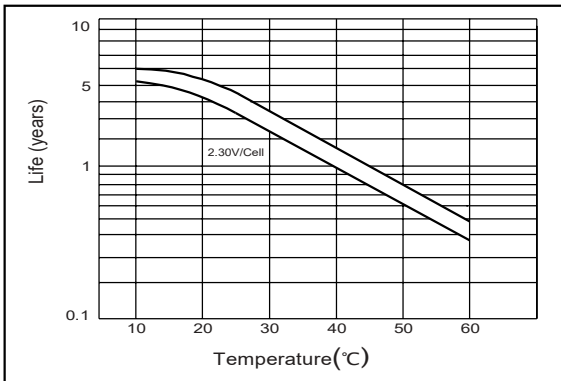

● Cycle life on D.O.D.(25°C)

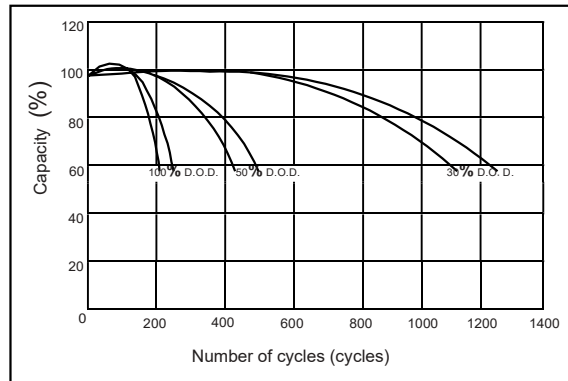

● The relationship for OCV and Capacity (25°C)

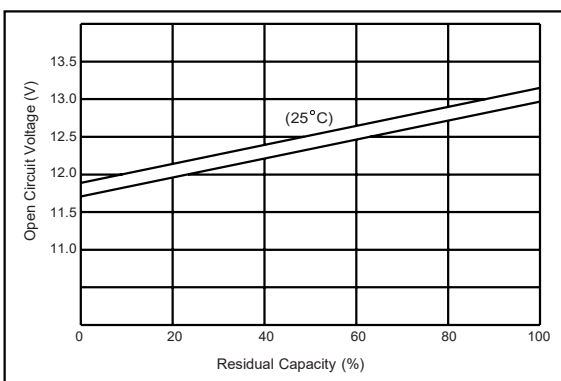

● The relationship for Charging voltage and Temperature

